

36 Series

Stainless Steel 2-way Full Port Ball Valve



USER'S MANUAL

Installation & Maintenance

TABLE OF CONTENTS

1. General Precaution	
1.1. Material Section	1
1.2. Pressure-Temperature Rating	1
1.3. Fluid Thermal Expansion	1
1.4. Static Electric Effect	1
1.5. Liquids with High Fluid Velocity	1
1.6. Throttling Service	1
1.7. Disassembling Valve	1
1.8. Skin Contact with the Valve Surface	1
1.9. Fluid Contact with the Valve	1
1.10. Locking Device	1
2. Product Description	
2.1. Feature	1
2.2. Product Specification	2
2.3. Dimensions	2
3. Design Specification	2
4. Pressure Temperature Rating	3
5. Delivery Condition and Storage	3
6. Valve Installation	
6.1. Handling	3
6.2. Cleaning	3
6.3. Flow Direction	3
6.4. Position and Weight Support	3
6.5. Installation of Threaded End Valve	4
6.6. Installation of Weld End Valve	4
6.7. Systems Hydrostatic Test	4
7. Valve Operation	
7.1. Manual Operation	4
7.2. Automatic Operation	4
8. Maintenance	
8.1. Maintenance Frequency	5
8.2. Disassembling and Cleaning the Valve	5
8.3. Replacing Seats and Joint Gaskets	5
8.4. Replacing Stem Sealing Components	5
9. Torque Data	
9.1. Valve Assembly Torque Table	6
9.2. Valve Operation Torque Table	6
10. Assembly Diagram	7

1. General Precaution

1.1. Material Section

Material deterioration is determined by the contained fluid. The need for period inspection must be determined by user based on the contained fluid. Among possible cases of deterioration are carbide phase conversion to graphite, oxidation of ferrite materials, decrease in ductility of carbon steels at low temperature (even in applications above -29°C). Although information about corrosion data is provided in this user's manual, the user should pay special attention to determine the suitability of material in his own specific application

1.2. Pressure-Temperature Rating

Stated rating is considered for static pressure only. Please refer to P & T rating section on page [3](#) for working precaution. The allowable temperature range is between ambient temperature and 200°C. DO NOT exceed the temperature range. Exceeding the temperature range could result in serious accidents

1.3. Fluid Thermal Expansion

When the valve is subjected to extreme variation in ambient temperature, fluid thermal expansion might cause the ball valve to exceed intended operating pressure. This condition tends to be more severe when the ball valve is left in closed position for a long period of time during extreme temperature variation. While our valve is designed to equalize the pressure within the ball valve cavities, the user must take measures to ensure that the valve does not exceed its rated pressure due to fluid thermal expansion

1.4. Static Electric Effect

The ball valve has an internal anti-static design. It is designed to provide electric continuity between ball, stem, and body. When service conditions require electrical continuity to prevent static discharge, the user is responsible for providing static grounding

1.5. Liquids with High Fluid Velocity

When your application calls for frequent high fluid velocity, please contact our distributor for advice on minimizing the possibility of seat deformation, especially when ball valves are subjected to high pressure and high temperature lines

1.6. Throttling Service

Ball valves are generally not recommended for throttling service. The fluid flow and the leading edge of the ball can damage or deform the resilient ball seats. High fluid velocity or the presence of solid particles in the pipeline will further reduce the seat life in throttling applications

1.7. Disassembling Valve

Do not disassemble or loosen any part of valve while it is under pressure. When the valve is not equipped with pressure sensing device, user should check the line pressure by other method through the piping system

1.8. Skin Contact with the Valve Surface

When the valve is in service, do not touch the valve surface until you can be sure that it is within the safe temperature range for touching

1.9. Fluid contact with the Valve

Do not use the valve on fluids that are corrosive or inappropriate to any part of the valve. Please review the corrosion data on page [8](#) for more information

1.10. Locking Device

To guard against valve being operated by unauthorized personnel, lockable ball valve is available as an option. However, the pad lock must be provided by the customer.

2. Product Description

2.1. Feature

- a. Full bore ball valve with ISO5211 mounting pad for direct mounting to actuator with DIN3337 standard
- b. Easily retrofitted with manual handle, double acting actuator, or single acting actuator

- c. Options of threaded end, socket weld end, or butt weld end with face to face dimensions according to DIN3202-M3
- d. Three-Piece design enables in-line maintenance
- e. Special pyramidal stem design for exceptional stem sealing during high cycle operation
- f. Blowout proof stem
- g. Anti-static design with electric continuity for ball, stem, and body
- h. Self pressure relief seat to prevent pressure built up
- i. Optional handle or lockable handle available to prevent unauthorized valve operation

2.2. Product Specification

Product Code	PN	NO CE Marking	CE Category II
MODEL 36T (THREADED) MODEL 36B (BUTT WELD) MODEL 36S (SOCKET WELD)	63	DN 8, DN10, DN15, DN20, DN25	DN32, DN40, DN50, DN65, DN80, DN100

2.3. Dimensions (mm)

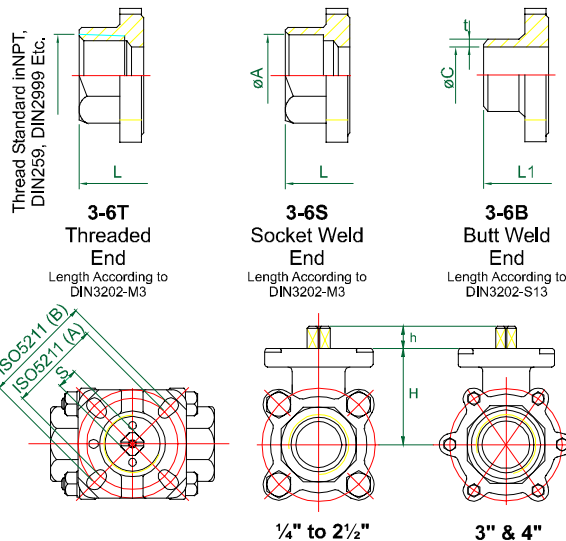

MATERIALS LIST

NO.	PART NAME	MATERIAL	Q'TY
1	Body	1.4408 or 1.0619	1
2	End Cap	1.4408 or 1.0619	2
3	Ball	SUS316	1
4	Seat	PTFE	2
5	Body Gasket	PTFE	2
6	Stem	SUS316	1
7	Pyramidal Stem Seal	PTFE	1
8	O-Ring	Viton	1
9	V-Ring Stem Packing	PTFE	†
10	Gland	SUS304	1
11	Belleville Washer	SUS301	2
12	Disc Plate	SUS304	1
13	Anti-Static Device	SUS316	2
14	Body Nut	ISO-3506 (A2-70)	§
15	Body Washer	ISO-3506 (A2-70)	§
16	Body Bolt	ISO-3506 (A2-70)	‡

§ ¼" to 2" = 4pcs; 2 ½" = 8pcs; 3" & 4" = 12pcs
 ‡ ¼" to 2" = 4pcs; 2 ½" = 4pcs studs; 3" & 4" = 6pcs studs
 † ¼" to ½" a set = 2pcs; 1" to 4" a set = 4pcs

DIMENSIONS (mm)

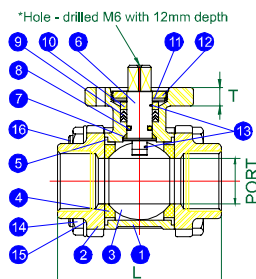

SIZE	DN	PORT	ØA	ØC	h	H	L	L1	S	T	t	ISO5211 (A)	ISO5211 (B)
¼"	8	11.5	14.2	10.4	7.0	42	65	70	9.0	9.5	2.2	PCD36 - Ø6	PCD42 - Ø6
⅜"	10	12.7	17.7	13.7	7.0	42	65	70	9.0	9.5	2.3	PCD36 - Ø6	PCD42 - Ø6
½"	15	15.0	21.9	15.0	7.0	42	75	75	9.0	9.5	3.0	PCD36 - Ø6	PCD42 - Ø6
¾"	20	20.0	27.3	21.4	8.0	45	80	90	9.0	9.5	3.0	PCD36 - Ø6	PCD42 - Ø6
1"	25	25.0	34.1	27.2	11.0	52	90	100	11.0	10.0	4.0	PCD42 - Ø6	PCD50 - Ø7
1 ¼"	32	32.0	43.0	35.5	11.0	57	110	110	11.0	10.0	4.0	PCD42 - Ø6	PCD50 - Ø7
1 ½"	40	38.0	49.0	41.2	14.0	68	120	125	14.0	13.0	4.0	PCD50 - Ø7	PCD70 - Ø9
2"	50	50.0	61.3	52.7	14.0	77	140	150	14.0	13.0	5.0	PCD50 - Ø7	PCD70 - Ø9
2 ½"	65	65.0	77.0	65.3	17.0	99	185	190	17.0	13.0	5.2	PCD70 - Ø9	PCD102 - Ø11
3"	80	80.0	89.9	78.0	17.0	111	205	220	17.0	13.0	5.5	PCD70 - Ø9	PCD102 - Ø11
4"	100	97.0	115.3	107.5	22.0	141	240	270	22.0	16.5	6.0	PCD102 - Ø11	PCD125 - Ø11

3. Design Specification

Items	Standards and Codes
Pressure and Temperature Rating Designed to	PrEN12516-1
Testing According to	PrEN 1226-1
Material of Casting (Body, Cap, Ball)	EN10213-4 for 1.4408 EN10213-4 for 1.4308 EN 10213-2 for 1.0619
Bolt and Nut	ISO-3506 (A2-70)

4. Pressure Temperature Rating

The pressure temperature rating of the ball valve is determined, not only by the valve shell material, but also by the sealing material of ball seat, stem packing, and body seal. Choice of sealing materials should be based on, all the factors including but not limited to, the service media, service temperature, service pressure, media velocity within the line, frequency of valve operation and size of the ball valve. The following chart shows pressure vs. temperature rating for non-shock fluid service for different seat material. Please refer to general precautions section on page 1 for more information

Pressure vs. Temperature Chart

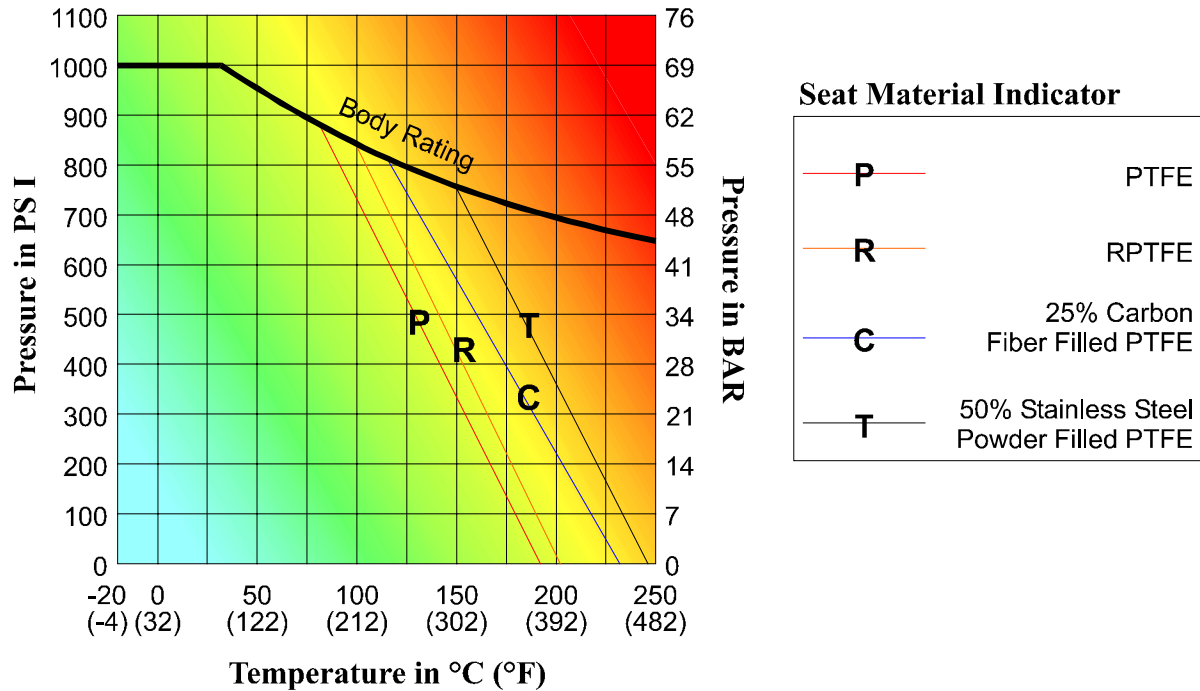

5. Delivery Condition and Storage

- Valves are set to open position and individually bagged prior to shipment
- Upon delivery, customer's quality control must check the package to make sure that the valves are not damaged during the shipping process
- Valves must also be checked for loosening of bolts due to shipment
- Valves should be stored indoors and in its original package

6. Valve Installation

6.1. Handling

To ensure safety, user must handle the valve with both hands so that the weight of the valve is equally distributed at both ends. If a hoist is used to lift large valve, user must make sure the hoist is strong enough to support the weight of the valve

6.2. Cleaning

To prevent damage to the seats and ball surface, the user must inspect the valve for dirt, burrs and welding residues prior to installation. Although all valves were cleaned and bagged prior to delivery, if for some unforeseen circumstances that the valves were soiled during transportation, the user must clean the valve prior to installation. The user may clean the valve by water, steam or pressurized air

6.3. Flow Direction

Our valves are bi-directional, meaning upstream or downstream could be at either end of the valve

6.4. Position and Weight Support

The weight of the valve must be properly supported by means other than the connected pipelines. The valve end connection and the pipeline forms an integral sealing zone. If

the weight of the valve is entirely distributed to the joint area, the valve will deform and cause leakage

6.5. Installation of Threaded End Valve

- a. Use conventional sealant, such as hemp core, PFA-lined, etc
- b. Use wrench and apply force on the hexagon end of the valve only. Apply force to other area of valve may seriously damage the valve
- c. For applications where threaded end valves are back-welded on site, the valves must be dismantled according to instructions for weld end valves

6.6. Installation of Weld End Valve

- a. Tack-weld the valve on the pipe in four points on both end caps.
- b. With the valve in open position (see valve position diagram on page 4), loosen all the nuts on the body bolts
- c. Remove all the bolts except one
- d. Swing the body outside the pipe
- e. Turn the handle to the half open position to assist in the removal of the seats and body gaskets
- f. Turn the handle to the closed position and remove the ball
- g. Place all removed parts in a clean and secure place
- h. Replace the body and the removed bolt. Tighten all nuts slightly. To prevent any leakage to the body joints after welding, make sure that the body and the end caps remain perfectly parallel
- i. Finish welding both end caps onto the pipe
- j. After the pipeline and valve cool, clean end caps then remove the previous replace bolt. Swing out the body. Turn the valve to the closed position, then replace the ball. Turn valve in open position and replace seats and body gaskets
- k. After seats, body gaskets and ball are replaced, swing the body into position, replace the removed bolts and nuts, and tighten the nuts according to the valve assembly torque table on page 6

6.7. Systems Hydrostatic Test

Before delivery, our valves are tested to 1.5 times the allowable pressure at ambient temperature in the open position. After installation, the pipeline may be subjected to system test pressure of no more than 1.5 times the rated pressure

7. Valve Operation

7.1. Manual Operation

Handle is offered as an option

- a. Valve in Open Position is indicated by handle in parallel (in-line) with the valve or pipeline
- b. Valve in Closed Position is indicated by handle in perpendicular (crossed with the valve or pipeline)

7.2. Automatic Operation

- a. Prior to actuator installation the position of the valve is indicated as shown in the illustrations below with a line indicator on top of the valve stem

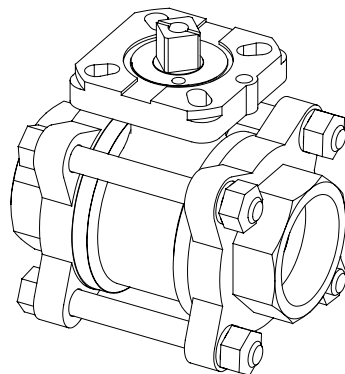

OPEN

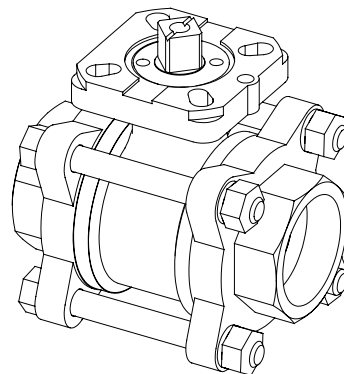

CLOSE

- b. After Actuator installation, valve should be check for valve stem alignment. Angular or linear misalignment will result in high operational torque and unnecessary wear on the stem seal

8. Maintenance

8.1. Maintenance Frequency

User should determine the maintenance frequency depending on specific application. If there is sign of leakage from the stem, it is time to replace the stem sealing components. If there is sign of internal leakage, it is time to replace the seats and gasket components. Life of the valve can be maximized if the valve is used within the rated range, in accordance with pressure, temperature, and corrosion data

8.2. Disassembling and Cleaning the Valve

Ball valve can trap fluids in ball cavity when it is in the closed position. If the valve has been used in hazardous media, it must be decontaminated before disassembly.

- a. Relieve the line pressure
- b. Place valve in half-open position and flush the line to remove any hazardous material from valve
- c. All persons involved in the removal and disassembly of the valve should wear proper protective clothing, such as face shield, glove, apron, etc

8.3. Replacing Seats and Joint Gaskets

Seat and joint gaskets should be replaced at the same time. Once the valve is disassembly for seat service, the gasket should also be replaced to ensure proper body sealing

- a. Follow the direction on Disassembling & Cleaning the valve. Make sure the pipeline is de-pressurized
- b. With the valve in open position (see valve position diagram on page [4](#)), loosen all the nuts on the body bolting. Remove all the bolts except one. Swing the body outside the pipe.
- c. Turn the handle to the half open position to assist in the removal of the seats
- d. Replace with a new set of seats and body gaskets
- e. Swing the body back into position. Replace the removed bolts, and tighten the bolts according the valve assembly torque table on page [6](#)

8.4. Replacing Stem Sealing Components

- a. Follow the direction for replacing the seats and joint gaskets from a. to c.
- b. To assist in loosening of the disc plate, place a rod of diameter smaller than the ball orifice into the ball orifice. Loosen and remove the disc plate with two-prone tool. Remove the set of Belleville washers and the gland. Place all removed parts in a clean and secure place
- c. Remove the rod. Turn the valve to the closed position (see valve position diagram on page [4](#)). Remove the seats and body gaskets. The ball should slide out with a gentle push. Place all removed parts in a clean and secure place
- d. Push the stem downward. It should come out through the center body. Remove the stem then remove the pyramidal stem seal. Thoroughly clean the stem. Replace with a new pyramidal stem seal.
- e. Remove the v-ring stem packing from the center body cavity. Thoroughly clean the center body. Replace with a new v-ring stem packing.
- f. Replace the stem, the Belleville washers and the gland. Replace the disc plate. To tighten the disc plate, hold the stem in place and tighten the disc plate with two-prone tool. Refer to the stem disc torque in the valve assembly torque table on page [6](#) for the correct torque value.
- g. Turn the valve to the closed position (see valve position diagram on page [4](#)).. Replace the ball. Turn the valve to the open position. Replace the seats and joint gaskets.
- h. Swing the center body back into position. Replace the removed bolts and nuts. Tighten the nuts according to valve assembly torque table on page [6](#).

9. Torque Data

9.1. Valve Assembly Torque Table

This torque table shows the required torque that is needed to tighten the valve stem and valve body bolt. It is very important that these torque values are applied with tolerance of no more or no less than 10%. Incorrect torque values might result in improper sealing of the valve or deformation of the bolts.

Size	Stem Disc Torque (NM)	Body Bolt Torque (NM)
1/4" DN8	12	8
3/8" DN10	12	8
1/2" DN15	12	18
3/4" DN20	12	18
1" DN25	17	18
1 1/4" DN32	17	34
1 1/2" DN40	24	34
2" DN50	24	59
2 1/2" DN65	35	113
3" DN80	35	113
4" DN100	40	113

9.2. Valve Operation Torque Table

The table below lists break torque values for PTFE seat in clear non-viscous fluid. Torque value can vary depending on temperature, pressure, line medium, and seat material

Differential Pressure	75 PSI		150 PSI		300 PSI		700 PSI		1000 PSI	
	5 BAR		10 BAR		20 BAR		50 BAR		63 BAR	
Valve Size	IN-LB	NM	IN-LB	NM	IN-LB	NM	IN-LB	NM	IN-LB	NM
1/4", 3/8" DN8/10	45	5.1	45	5.1	45	5.1	45	5.1	45	5.1
1/2" DN15	60	6.8	60	6.8	60	6.8	60	6.8	60	6.8
3/4" DN20	80	9.0	80	9.0	80	9.0	80	9.0	80	9.0
1" DN25	130	14.7	130	14.7	130	14.7	130	14.7	130	14.7
1 1/4" DN32	160	18.1	160	18.1	160	18.1	180	20.3	190	21.5
1 1/2" DN40	200	22.6	200	22.6	260	29.4	300	33.9	350	39.5
2" DN50	280	31.6	375	42.4	400	45.2	450	50.8	480	54.2
2 1/2" DN65	500	56.5	600	67.8	620	70.1	800	90.4	-	-
3" DN80	650	73.4	800	90.4	900	101.7	1300	146.9	-	-
4" DN100	1100	124.3	1500	169.5	1900	214.7	2400	271.2	-	-

- For dry gas, increase the above torque value by 15%
- For viscous fluid or fluids with solid or abrasive contents, increase the above torque value by 35%
- For 15% glass fiber filled PTFE (RPTFE) seats, increase the above torque value by 15%
- For 25% carbon fiber filled PTFE (CTFE) seats, increase the above torque value by 25%
- For 50% stainless steel powder filled PTFE seats, increase the above torque value by 25%
- A safety factory of 20% is recommended for actuator sizing

10. Assembly Diagram

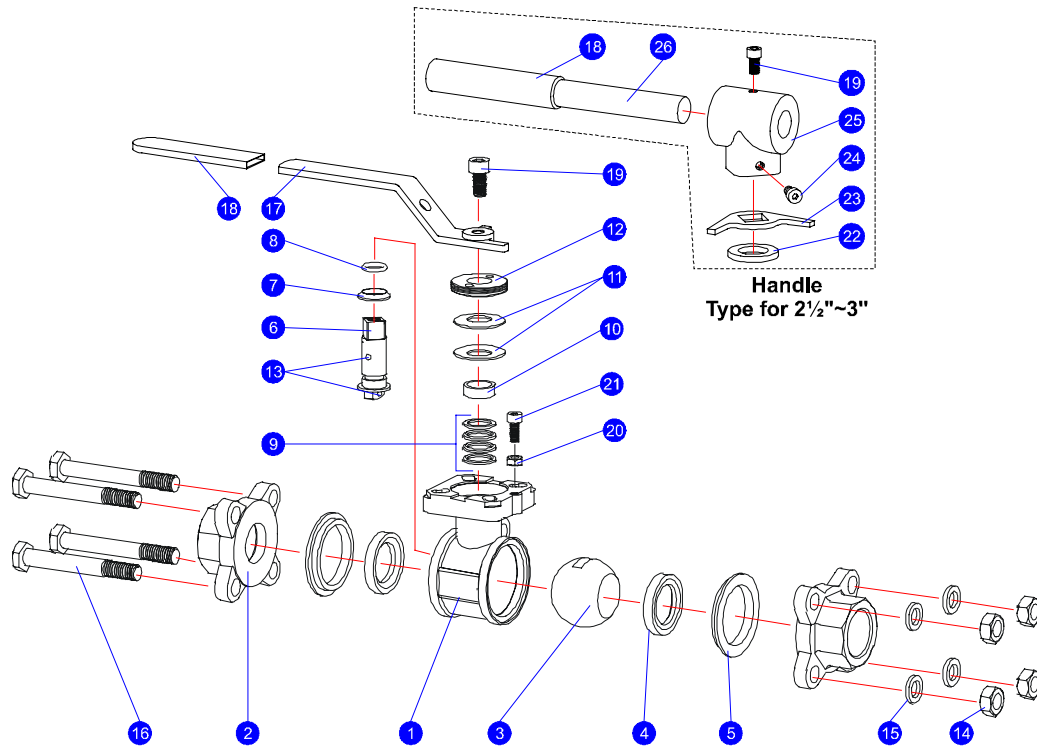

MATERIALS LIST

NO.	PART NAME	MATERIAL	Q'TY
1	Body	1.4408 or 1.0619	1
2	End Cap	1.4408 or 1.0619	2
3	Ball	SUS316	1
4	Seat	PTFE	2
5	Body Gasket	PTFE	2
6	Stem	SUS316	1
7	Pyramidal Stem Seal	PTFE	1
8	O-Ring	Viton	1
9	V-Ring Stem Packing	PTFE	†
10	Gland	SUS304	1
11	Belleville Washer	SUS301	2
12	Disc Plate	SUS304	1
13	Anti-Static Device	SUS316	2
14	Body Nut	ISO-3506 (A2-70)	§
15	Body Washer	ISO-3506 (A2-70)	§
16	Body Bolt	ISO-3506 (A2-70)	‡

§ ¼" to 2" = 4pcs; 2 ½" = 8pcs; 3" & 4" = 12pcs
 ‡ ¼" to 2" = 4pcs; 2 ½" = 4pcs studs; 3" & 4" = 6pcs studs
 † ¼" to ¾" a set = 2pcs; 1" to 4" a set = 4pcs

Material List for Optional Handle Kit

NO.	PART NAME	MATERIAL	Q'TY
17	Handle	SUS304	1
18	Handle Sleeve	Vinyl	1
19	Handle Bolt	SUS304	1
20	Stop Bolt	SUS304	1
21	Stop Nut	SUS304	1
22	Handle Spacer	PTFE	1
23	Stop Plate	SUS304	1
24	Adapter Bolt	SUS304	1
25	Handle Adapter	SUS304	1
26	Round Handle	SUS304	1

Items 17 to 19 are for ½" to 2" valves. Items 18 to 26 are for 2 ½" to 4" valves